

**Double Acting Door** – Center door in opening before tightening clamping screw.  
**Single Acting Door** – Clamp arm on spindle 5° past closed position of door.

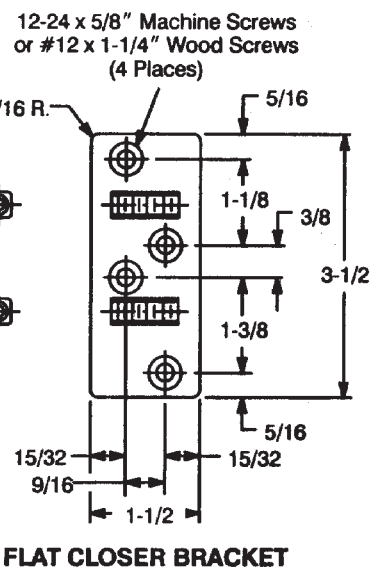
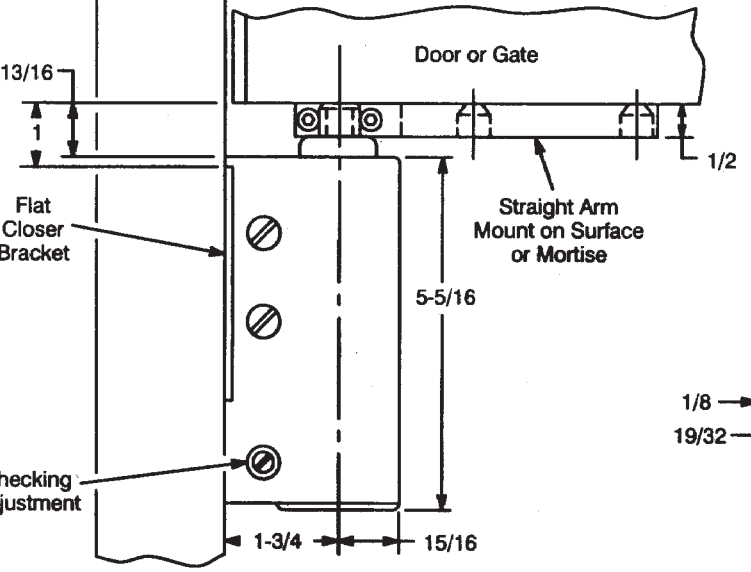
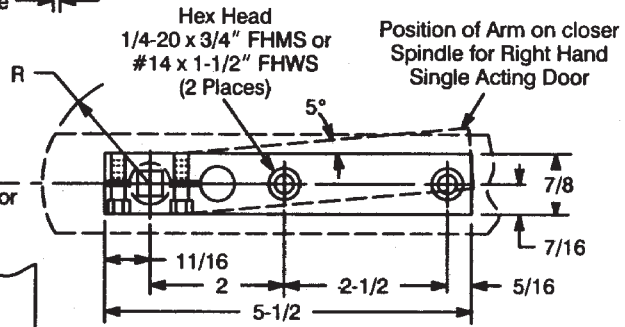

**INSTRUCTIONS:**

1. For straight arm, the arm may be clamped on the closer spindle to bring the door to rest at any position desired. If it is desired to have the door open to 90° and stop at this point, set the arm at 90° to the closer. On single acting doors closing against a stop, the arm is set at an angle of 5° past the closed position of the door to insure tight closing against the door stop.
2. **THE ARM CLAMPING SCREWS MUST BE TIGHT.** Use wrench supplied. The door is then hung. The last operation is to screw the arm tightly to the bottom of the door.  
**DOUBLE ACTING DOOR:**  
 If the door does not center properly in the opening, **loosen the arm clamping screw** until the door swings free on the knurled bushing on the closer spindle. Move the door to the desired position and again **tighten the clamping screws. (BE SURE THEY ARE VERY TIGHT.)**
3. Adjust the closing speed of the door with the valve located near the bottom of the closer, so that the door closes as quickly as possible without slamming.  
**DOUBLE ACTING DOOR:**  
 Adjust the valve so that there is no "flip-flap" at closed position.

**Notes:**

1. Do not scale drawing.
2. Specify wood or machine screws for jamb.  
 Specify wood or machine screws for door or gate.  
 Specify thickness of door or gate.
3. All dimensions given in inches.

**356 Gate Closer**

**RIXSON**  
**ASSA ABLOY**

www.rixson.com

TEMPLATE NUMBER	DATE
<b>CH20610</b>	<b>02-09</b>